

Micron Transformers

“Made with pride in the USA”

**Catalog
CCT-04C**

NEW IMPERVITRAN DESIGNS

PAGES 9-20

NEW IP-20 FUSEBLOCK COVERS

PAGES 21-22

**Effective Date:
December 1, 2004**

Supersedes: GC-803, GT-804

MICRON INDUSTRIES CATALOG CCT-04C

REPLACES GC-803 AND GT-804

Table of Contents

<i>THE MICRON EDGE</i>	2
- Warranty	
Transformer Selection Process	3-4
Transformer Product Line Overview	5-6
Markets Served	7
Standards	8
-UL/CSA	
-IEC	
ImperviTRAN	9-20
Accessories	21-22
GlobalTRAN	23-27
Medium Voltage	28
Overcurrent Protection Tables	29-30

THE MICRON EDGE

**While other manufacturers
treat transformers as
just one of a variety of
products, transformers
are THE major product
focus for Micron**

**This focus and resulting
commitment to excellence,
exemplified in our
unprecedented 20-year
warranty¹, has made
Micron**

#1

**with specifiers of
transformers
for over 30 years.**

¹ 20 years applies to all 600 volt class product.
LVGP and Medium Voltage are warranted for
one year.

TRANSFORMER SELECTION PROCESS

Determining Inrush and Voltage Requirements

Selecting a transformer for industrial control circuit applications requires knowledge of the following terms:

INRUSH VA is the product of the load voltage (V) multiplied by the current (A) that is required during start-up. It is calculated by adding the inrush VA requirements of all devices (contactors, timers, relays, pilot lights, solenoids, etc.), which will be energized together. Inrush VA requirements are best obtained from the component manufacturer.

SEALED VA also called Steady State VA, is the product of the load voltage (V) multiplied by the current (A) that is required to operate the circuit after initial start-up or under normal operating conditions. It is calculated by adding the sealed VA requirements of all electrical components of the circuit that will be energized at any given time. Sealed VA requirements are best obtained from the component manufacturer.

PRIMARY VOLTAGE is the voltage available from the electrical distribution system and its operational frequency, which is connected to the transformer supply voltage (H) terminals.

SECONDARY VOLTAGE is the voltage required for load operation, which is connected to the transformer load voltage (X) terminals.

Once the circuit variables have been determined, transformer selection is a simple 5-step process as follows:

1. Determine the Application Inrush VA by using the following industry accepted formula.

$$\text{Application Inrush VA} = \sqrt{(\text{INRUSH VA})^2 + (\text{SEALED VA})^2}$$

2. Refer to the Regulation Data Chart. If the primary voltage is basically stable and does not vary by more than 5% from nominal, the 90% secondary voltage column should be used. If the primary voltage varies between 5 and 10%, the 95% secondary voltage column should be used.
3. After determining the proper secondary voltage column, read down until a value equal to or greater than the Application Inrush VA is found. In no case should a lesser figure be used.
4. Read left to the Transformer VA Rating column to determine the proper transformer for the application. As a final check, make sure that the Transformer VA Rating is equal to or greater than the total sealed VA requirements.
5. Refer to the catalog pages to determine the proper catalog number based on the transformer VA and primary and secondary voltage requirements.

REGULATION DATA CHART

Transformer VA Rating	Inrush VA at 20% Power factor		
	NEMA / IEC 95% Sec. Voltage	NEMA / IEC 90% Sec. Voltage	NEMA / IEC 85% Sec. Voltage
25	100 / ----	130 / ---	150 / ---
50	170 / 190	200 / 220	240 / 270
75	310 / 350	410 / 460	540 / 600
100	370 / 410	540 / 600	730 / 810
150	780 / 850	930 / 1030	1150 / 1270
200	810 / 900	1150 / 1270	1450 / 1600
250 ¹	1400 / 1540	1900 / 2090	2300 / 2530
250 ²	860 / 960	1120 / 1350	1590 / 1770
300 ¹	1900 / 2090	2700 / 2970	3850 / 4240
300 ²	1170 / 1300	1760 / 1960	2360 / 2620
350 ¹	3100 / 3410	3650 / 4020	4800 / 5280
350 ²	1310 / 1460	2040 / 2270	2770 / 3090
500 ¹	4000 / 4400	5300 / 5830	7000 / 7700
500 ²	1970 / 2180	3020 / 3360	4080 / 4530
750 ¹	8300 / 9130	11000 / 12100	14000 / 15400
750 ²	3030 / 3370	4560 / 5070	6100 / 6780
1000 ¹	15000 / 16500	21000 / 23000	27000 / 29500
1000 ²	9000 / 9900	13000 / 14300	18500 / 20300
1500	10500 / 11500	15000 / 16500	20500 / 22500
2000	17000 / 18900	25500 / 27300	34000 / 36400
3000	24000 / 25700	36000 / 38500	47500 / 50200
5000	55000 / 58800	92500 / 98900	115000 / 122000

To comply with NEMA standards, which require all magnetic devices to operate successfully at 85% of rated voltage, the 90% secondary column is most often used in selecting a transformer. No comparable requirement is available for IEC.

¹ For units with class 105° C insulation system.

² For units with class 180° C insulation system.

MICRON INDUSTRIES CORPORATION

STATEMENT OF BUSINESS PHILOSOPHY

Micron Industries Corporation is a specialized transformer manufacturer. Product offerings are chosen carefully in order to provide the best available product. We deliberately choose to be highly selective and not just a "me-too" supplier of all transformer products. By policy and desire we have developed unparalleled expertise in application, design and manufacturability of the products we offer. Our mission is to provide complete customer satisfaction.

THE HISTORY OF IMPERVITRAN

Micron Industries Corporation, headquartered in Elmhurst, Illinois, is a designer and manufacturer of transformers. Micron's products are sold nationwide through a system of sales representatives and stocking distributors.

Micron's products are used extensively in industrial, commercial, and military markets. Products include control, power transformers and medium voltage control transformers.

In the mid 1960's Micron began as a custom coil winder for other transformer companies. In 1970 the Company expanded into the manufacturing of transformers, developing a patented epoxy encapsulated control transformer, known as **ImperviTRAN**. For over 30 years, this product has been nationally recognized as the quality control transformer that assists the user in reducing installed and life cost of system applications.

Micron has become known as the innovator of the industry. ImperviTRAN was the first control transformer with integral secondary fusing, molded terminal barriers to protect against electrical creepage, encapsulation for maximum protection in industrial and hostile operating environments.

In response to NEC changes, Micron was the first to add primary fusing to its transformer. Also, Micron added phillslot head (combined blade and phillips) terminal screws to its products to assist OEM's and users in the installation process.

In 1996, Micron redesigned its terminal configurations to accept our proprietary SafeTouch IEC-529/IP20 covers for both the primary and secondary side of the transformer. In addition, the SafeTouch series of covers offers the same degree of protection for Micron's primary fusing options.

In 2003, Micron achieved UL/CSA recognition to build the ImperviTRAN in all three major temperature classes; 105°C, 130°C and 180°C. This allows an optimal design best fitting the customer application.

The Micron product offering covers one of the widest selections of VA sizes and voltage ranges in the industry based on the concept of designing unique competitive features and benefits into each product category. This design concept currently embraces not only ImperviTRAN, it is the major design force

SPECIFIC PRODUCTS

ImperviTRAN The Micron "hallmark product" offering, servicing the markets as the best Industrial Control Circuit Transformer available. All ImperviTRAN designs are UL listed and CSA certified. ImperviTRAN product is serviced through distribution with factory backup stock, thus creating a Micron competitive edge. ImperviTRAN is competitively priced with other designs (encapsulated and open construction) yet continues to command a price value equal to the installed cost, life cost and associated benefits such as Micron's standard secondary fuse clip and optional dual primary fuse block. ImperviTRAN is built in three major temperature classes. The following ending letter identifies part numbers not designed as Class 105°C: "F" (130°C), "H" (180°C)

GlobalTRAN, Is built to meet the demanding requirements of IEC-60742 and IEC-61558 as governed by the CB Scheme and carries the CE mark. GlobalTRAN is available from stock in many voltage combinations or can be designed to meet customer specifications. GlobalTRAN is built in three major temperature classes. The following ending letter identifies part numbers not designed as Class 105°C: "F" (130°C), "H" (180°C)

EconoTRAN, Compliments Micron's current line by offering control transformers through 5KVA utilizing a 180°C insulation system. The EconoTRAN line can be designed in VA sizes and termination configurations to suit the application.

Low Voltage General Purpose, Single and three phase in both encapsulated and ventilated construction. Designed to fill the needs of a harsh industrial environment.

Micron's excellent history of quality has led to an unprecedented 20-year warranty on all ImperviTRAN, GlobalTRAN, ValuTRAN or EconoTRAN transformers rated 600 volts and below.

Medium Voltage Control Transformers are available from Micron to fill most medium voltage to control voltage needs. The product class is available with either 2400 or 4160 volt primaries and 120/240 volt secondaries as standard. Custom voltages and VA designs are available for specific applications.

Other Products: Specific product designs can be developed to capture market opportunities; consult factory for assistance.

MARKETS SERVED

A control transformer steps down the voltage in a power circuit in order to safely operate control devices (contactors, relays, pushbuttons, etc.). Typical control voltages are 120 or 24 volts AC. There are also times when other output voltages are necessary (instrumentation, flow meters, PLCs, etc). Micron can provide a transformer to fit the needs of the most demanding input or control voltage application. Feel free to contact Micron or our local representative with your control voltage requirements. A few of the markets we serve are as follows:

Industrial Equipment

Compressors
 Dock levelers
 Heat treat ovens
 Fire pump controllers
 HVAC systems
 Motor control centers
 Paint systems
 Waste compactors
 Water purification
 Welding equipment
 Hydraulic power packs
 Crane and hoist controls
 Sorting equipment
 Laser controls
 Door actuators
 Environmental chambers
 Palletizing equipment

Food Service Equipment

Baking ovens
 Deep fryers
 Dishwashers
 Grinders
 Steam ovens
 Water heaters
 Ventilators
 Chillers

Mainframe Equipment

Alarm systems
 Auxiliary power systems
 HVAC systems, controls and drives
 Transfer switches
 Voltage regulation

Agricultural

Incubation equipment
 Irrigation and aeration
 Grain drying and handling

Commercial Applications

Elevator controls
 Building management systems
 Commercial laundry equipment
 Low voltage decorative lighting
 Transfer switches
 Car wash systems
 Chillers
 Waste management systems
 Alarm systems

We welcome your calls on any issue regarding how Micron can be of service to you.

Telephone	630-516-1222 800-664-4660	(6:00 a.m. to 5:00 p.m. central time) (Voice mail available 24 hours)
Fax	630-516-1820	(24 hours)
E-mail	sales@microntransformers.com	
Website	www.microntransformers.com	

INDUSTRY AND INTERNATIONAL STANDARDS

Micron offers a broad line of standard transformers, each made with the finest materials and workmanship. Laminations of high-grade silicon steel assure optimum performance and the finest quality copper magnet wire assures efficient operation. Insulation materials are of the highest rating available for the temperature class and mounting brackets of heavy gauge steel add strength and stability. All are UL 506 listed (File # E46323) and CSA certified (File # LR27533) and meet NEMA and ANSI requirements.

In response to the change in compliance standards for CE marking of industrial control transformers as required by IEC/EN guidelines, Micron has introduced new GlobalTRAN models in compliance with EN61558-2. This new IEC/EN standard replaces the previous IEC/EN 60742 standard for control power transformers that expired on December 31, 2003. The Micron design engineering department has produced 61558-2 compliant designs that permit the customer to retain mounting layouts used for the previous Micron 60742 designs.

GlobalTRAN® products carry the CE mark, certifying 100% compliance with requirements of EN61558 for Non-Short Circuit Proof Isolating Transformers. GlobalTRAN control transformers feature touch-proof terminals, utilizing either Micron's SafeTouch terminal covers or a touch-proof terminal block, and meet true IP-20 or IP-00 terminal protection ratings as defined by IEC-529.

Of course, all GlobalTRAN products also carry the UL listing and CSA certification.

GlobalTRAN is the most reliable and versatile control transformer in the industry today.

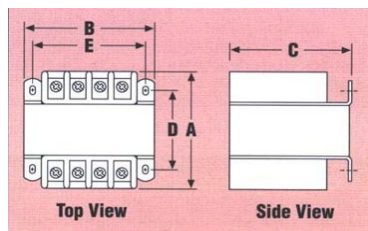

**DIMENSIONS: IMPERVITRAN
P/N BEGINNING "B"**

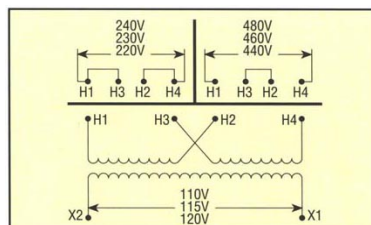

**CONNECTION DIAGRAM:
GROUP "A"**

CONTROL TRANSFORMERS:

All are UL Listed, CSA Certified and 50/60 Hz

GROUP "A"

CATALOG NUMBER	UPC # 784550	OUTPUT VA	AMPS	DIMENSIONS INCHES (MM)										MOUNTING SLOTS		APPROX. WEIGHT	
				A		B		C		D		E		IN	MM	LBS	KG
VOLTAGE:				IN	MM	IN	MM	IN	MM	IN	MM	IN	MM	IN	MM		
PRI: 220x440, 230x460, 240x480 SEC: 110/115/120																	
B050BTZ13JK	003499	50	0.43	3 1/8	79	3	76	2 9/16	65	2	51	2 1/2	64	.203 X .460	5 X 12	2.6	1.2
B050BTZ13RB	003543							3 15/16	99								
B075BTZ13JK	005769	75	0.65	3 5/8	92	3	76	2 9/16	65	2 1/2	64	2 1/2	64	.203 X .460	5 X 12	3.5	1.6
B075BTZ13RB	005790							3 15/16	99								
B100BTZ13JK	008166	100	0.87	3 7/16	87	3 3/8	86	2 7/8	73	2 3/8	60	2 13/16	71	.203 X .460	5 X 12	4.2	1.9
B100BTZ13RB	008227							4 1/4	107								
B150BTZ13JKF	047844	150	1.30	3 5/8	92	3 3/4	95	3 3/16	81	2 13/16	71	3 1/8	79	.203 X .460	5 X 12	5.6	2.5
B150BTZ13RBF	047899							4 9/16	115								
B200BTZ13JKF	047868	200	1.74	3 3/4	95	4 1/2	114	3 7/8	99	2 7/16	62	3 3/4	95	.203 X .460	5 X 12	7.0	3.2
B200BTZ13RBF	048001							5 1/4	133								
B250BTZ13JKF	047837	250	2.17	4	102	4 1/2	114	3 7/8	99	2 13/16	71	3 3/4	95	.203 X .460	5 X 12	9.5	4.3
B250BTZ13RBF	048025							5 1/4	133								
B300BTZ13JKF	047974	300	2.61	4 3/8	111	4 1/2	114	3 13/16	97	3 3/16	81	3 3/4	95	.203 X .460	5 X 12	11.0	5.0
B300BTZ13RBF	048094							5 3/16	131								
B350BTZ13JKF	047875	350	3.04	4 3/4	121	4 1/2	114	3 7/8	99	3 3/4	95	3 3/4	95	.203 X .460	5 X 12	12.0	5.5
B350BTZ13RBF	048032							5 1/4	133								
B500BTZ13JKF	048179	500	4.35	5 1/8	130	5 1/4	133	4 1/2	114	3 7/8	99	4 3/8	111	.313 X 1.063	8 X 27	15.0	6.8
B500BTZ13RBF	048247							5 7/8	148								
B750BTZ13JKF	048230	750	6.52	6 5/8	168	5 1/4	133	4 1/2	114	5 3/8	137	4 3/8	111	.313 X 1.063	8 X 27	25.0	11.4
B750BTZ13RBF	048254							5 7/8	148								
B1K0BTZ13JKF	049152	1000	8.70	6 7/16	164	6 3/4	171	5 3/4	146	3 7/8	99	6 1/8	156	.313 X .781	8 X 20	26.5	12.0
B1K0BTZ13RBF	055535							7 1/8	180								
B1K5BTZ13JKH	058857	1500	13.04	7	178	6 3/4	171	5 3/4	146	4 1/4	108	6 1/8	156	.313 X .750	8 X 19	34.0	15.5
B1K5BTZ13RBH	059144							7 1/8	180								
B2K0BTZ13JKH	057973	2000	17.39	8 1/8	207	6 3/4	171	5 3/4	146	5 1/2	140	6 1/8	156	.281 X .562	7 X 14	36.8	16.7
B2K0BTZ13RBH	059151							7 1/8	180								
B3K0BTZ13JXH	058512	3000	26.09	8 1/16	205	9	229	7 1/2	191	5 1/4	133	7 1/2	191	.440 X .910	11 X 23	55.9	25.4
B5K0BTZ13JXH	058505	5000	43.48	10	254	9	229	10 3/16	259	7 3/16	183	7 1/2	191	.440 X .910	11 X 23	84.4	38.3

NOTE: RB, RBF, RBH SUFFIX = PRIMARY CL "CC" FUSE BLOCK ATTACHED. DIMENSION "C" CHANGE NOTED.
JXH HAS NO PROVISION FOR SECONDARY FUSING.

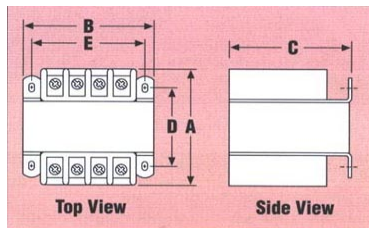

**DIMENSIONS: IMPERVITRAN
P/N BEGINNING "B"**

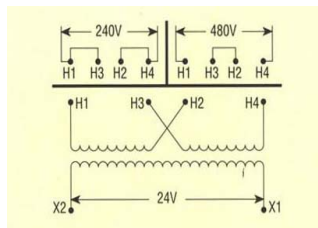

**CONNECTION DIAGRAM:
GROUP "B"**

**CONTROL TRANSFORMERS:
GROUP "B"**

All are UL Listed, CSA Certified and 50/60 Hz

CATALOG NUMBER	UPC # 784550	OUTPUT		DIMENSIONS INCHES (MM)										MOUNTING SLOTS		APPROX. WEIGHT	
		VA	AMPS	A		B		C		D		E		IN	MM	LBS	KG
VOLTAGE:				IN	MM	IN	MM	IN	MM	IN	MM	IN	MM	IN	MM		
PRI: 240x480																	
SEC: 24																	
B050PU7JK	004052	50	2.08	3 1/8	79	3	76	2 9/16	65	2	51	2 1/2	64	.203 X .460	5 X 12	2.6	1.2
B050PU7RB	004083							3 15/16	99								
B075PU7JK	006049	75	3.13	3 5/8	92	3	76	2 9/16	65	2 1/2	64	2 1/2	64	.203 X .460	5 X 12	3.5	1.6
B075PU7RB	006063							3 15/16	99								
B100PU7JK	008685	100	4.17	3 7/16	87	3 3/8	86	2 7/8	73	2 3/8	60	2 13/16	71	.203 X .460	5 X 12	4.2	1.9
B100PU7RB	008715							4 1/4	107								
B150PU7JKF	048308	150	6.25	3 5/8	92	3 3/4	95	3 3/16	81	2 13/16	71	3 1/8	79	.203 X .460	5 X 12	6.0	2.7
B150PU7RBF	059212							4 9/16	115								
B200PU7JKF	048315	200	8.33	3 3/4	95	4 1/2	114	3 7/8	99	2 7/16	62	3 3/4	95	.203 X .460	5 X 12	8.0	3.6
B200PU7RBF	059229							5 1/4	133								
B250PU7JKF	048322	250	10.42	4	102	4 1/2	114	3 7/8	99	2 13/16	71	3 3/4	95	.203 X .460	5 X 12	10.0	4.6
B250PU7RBF	059236							5 1/4	133								
B300PU7JKF	048339	300	12.50	4 3/8	111	4 1/2	114	3 7/8	99	3 3/16	81	3 3/4	95	.203 X .460	5 X 12	12.0	5.5
B300PU7RBF	059243							5 1/4	133								
B350PU7JKF	048346	350	14.58	4 3/4	121	4 1/2	114	3 7/8	99	3 3/4	95	3 3/4	95	.230 X .460	5 X 12	13.0	5.9
B350PU7RBF	059250							5 1/4	133								
B500PU7JKF	048353	500	20.83	5	127	5 1/4	133	4 1/2	114	3 7/8	99	4 3/8	111	.313 X 1.063	8 X 27	16.0	7.3
B500PU7RBF	059267							5 7/8	148								
B750PU7JXF	053883	750	31.25	6 3/8	162	5 1/4	133	4 1/2	114	5 3/8	137	4 3/8	111	.313 X 1.063	8 X 27	28.0	12.8
B750PU7RCF	059274							5 7/8	148								

NOTE: RB, RBF, RCF SUFFIX = PRIMARY CL "CC" FUSE BLOCK ATTACHED. DIMENSION "C" CHANGE NOTE
JXF, RCF SUFFIX HAS NO PROVISION FOR SECONDARY FUSING.

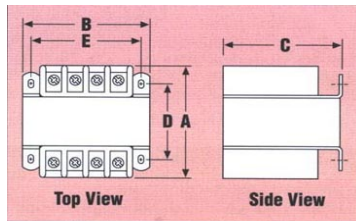

**DIMENSIONS: IMPERVITRAN
P/N BEGINNING "B"**

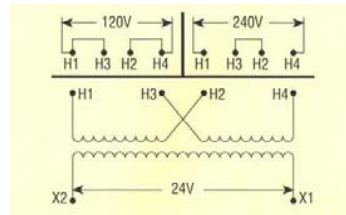

**CONNECTION DIAGRAM:
GROUP "C"**

**CONTROL TRANSFORMERS:
GROUP "C"**

All are UL Listed, CSA Certified and 50/60 Hz

CATALOG NUMBER	UPC # 784550	OUTPUT		DIMENSIONS INCHES (MM)										MOUNTING SLOTS		APPROX. WEIGHT	
		VA	AMPS	A		B		C		D		E		IN	MM	LBS	KG
VOLTAGE: PRI: 120x240 SEC: 24				IN	MM	IN	MM	IN	MM	IN	MM	IN	MM	IN	MM		
B050LP7JK	003758	50	2.08	3 1/8	79	3	76	2 9/16	65	2	51	2 1/2	64	.203 X .460	5 X 12	2.6	1.2
B050LP7RB	003796							3 15/16	99								
B075LP7JK	005875	75	3.13	3 5/8	92	3	76	2 9/16	65	2 1/2	64	2 1/2	64	.203 X .460	5 X 12	3.5	1.6
B075LP7RB	005899							3 15/16	99								
B100LP7JK	008418	100	4.17	3 7/16	87	3 3/8	86	2 7/8	73	2 3/8	60	2 13/16	71	.203 X .460	5 X 12	4.2	1.9
B100LP7RB	008449							4 1/4	107								
B150LP7JKF	048421	150	6.25	3 5/8	92	3 3/4	95	3 3/16	81	2 13/16	71	3 1/8	79	.203 X .460	5 X 12	6.0	2.7
B150LP7RBF	059281							4 9/16	115								
B200LP7JKF	048438	200	8.33	3 3/4	102	4 1/2	114	3 7/8	99	2 7/16	62	3 3/4	95	.203 X .460	5 X 12	8.0	3.6
B200LP7RBF	059298							5 1/4	133								
B250LP7JKF	053890	250	10.42	4	102	4 1/2	114	3 7/8	99	2 13/16	71	3 3/4	95	.203 X .460	5 X 12	10.0	4.6
B250LP7RBF	059304							5 1/4	133								
B300LP7JKF	048384	300	12.50	4 3/8	111	4 1/2	114	3 7/8	99	3 3/16	81	3 3/4	95	.203 X .460	5 X 12	12.0	5.5
B300LP7RBF	059311							5 1/4	133								
B350LP7JKF	048377	350	14.58	4 3/4	121	4 1/2	114	3 7/8	99	3 3/4	95	3 3/4	95	.230 X .460	5 X 12	13.0	5.9
B350LP7RBF	059328							5 1/4	133								
B500LP7JKF	048360	500	20.83	5	127	5 1/4	133	4 1/2	114	3 7/8	99	4 3/8	111	.313 X 1.063	8 X 27	16.0	7.3
B500LP7RBF	059335							5 7/8	148								
B750LP7JXF	053913	750	31.25	6 3/8	162	5 1/4	133	4 1/2	114	5 3/8	137	4 3/8	111	.313 X 1.063	8 X 27	28.0	12.8
B750LP7RCF	059342							5 7/8	148								

NOTE: RB, RBF SUFFIX = PRIMARY CL "CC" FUSE BLOCK ATTACHED. DIMENSION "C" CHANGE NOTED.
JXF, RCF HAS NO PROVISION FOR SECONDARY FUSING.

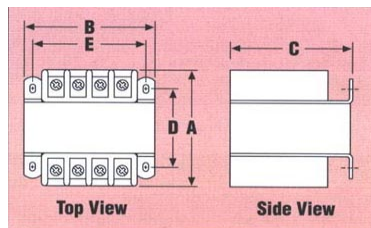

**DIMENSIONS: IMPERVITRAN
P/N BEGINNING "B"**

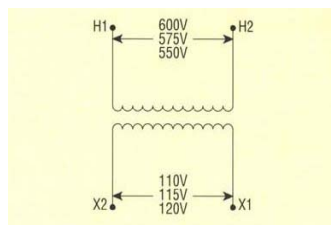

**CONNECTION DIAGRAM:
GROUP "E"**

**CONTROL TRANSFORMERS:
GROUP "E"**

All are UL Listed, CSA Certified and 50/60 Hz

CATALOG NUMBER	UPC # 784550	OUTPUT		DIMENSIONS INCHES (MM)								MOUNTING SLOTS		APPROX. WEIGHT			
		VA	AMPS	A		B		C		D		E		IN	MM	LBS	KG
VOLTAGE:				IN	MM	IN	MM	IN	MM	IN	MM	IN	MM	IN	MM		
PRI: 550/575/600 SEC: 110/115/120																	
B050WZ13XK	004441	50	0.43	3 1/8	79	3	76	2 9/16	65	2	51	2 1/2	64	.203 X .460	5 X 12	2.6	1.2
B050WZ13RK	004410							3 15/16	99								
B075WZ13XK	006193	75	0.65	3 5/8	92	3	76	2 9/16	65	2 1/2	64	2 1/2	64	.203 X .460	5 X 12	3.5	1.6
B075WZ13RK	006179							3 15/16	99								
B100WZ13XK	008944	100	0.87	3 7/16	87	3 3/8	86	2 7/8	73	2 3/8	60	2 13/16	71	.203 X .460	5 X 12	4.2	1.9
B100WZ13RK	008913							4 1/4	107								
B150WZ13XKF	048568	150	1.30	3 5/8	92	3 3/4	95	3 3/16	81	2 13/16	71	3 1/8	79	.203 X .460	5 X 12	6.0	2.7
B150WZ13RKF	054590							4 9/16	115								
B200WZ13XKF	048575	200	1.74	3 3/4	95	4 1/2	114	3 7/8	99	2 3/8	62	3 3/4	95	.203 X .460	5 X 12	7.0	3.2
B200WZ13RKF	052213							5 1/4	133								
B250WZ13XKF	048582	250	2.17	4	102	4 1/2	114	3 7/8	99	2 13/16	71	3 3/4	95	.203 X .460	5 X 12	10.0	4.6
B250WZ13RKF	054606							5 1/4	133								
B300WZ13XKF	048599	300	2.61	4 3/8	111	4 1/2	114	3 7/8	99	3 3/16	81	3 3/4	95	.203 X .460	5 X 12	12.0	5.5
B300WZ13RKF	054675							5 1/4	133								
B350WZ13XKF	048605	350	3.04	4 3/4	121	4 1/2	114	3 7/8	99	3 3/4	95	3 3/4	95	.203 X .460	5 X 12	14.0	6.4
B350WZ13RKF	054705							5 1/4	133								
B500WZ13XKF	048612	500	4.35	5	127	5 1/4	133	4 1/2	114	3 7/8	99	4 3/8	111	.313 X 1.063	8 X 27	16.0	7.3
B500WZ13RKF	054729							5 7/8	148								
B750WZ13XKF	048629	750	6.52	6 5/8	168	5 1/4	133	4 1/2	114	5 3/8	137	4 3/8	111	.313 X 1.063	8 X 27	25.3	11.5
B750WZ13RKF	054736							5 7/8	148								

NOTE: RK,RKF SUFFIX = PRIMARY CL "CC" FUSE BLOCK ATTACHED. DIMENSION "C" CHANGE NOTED.

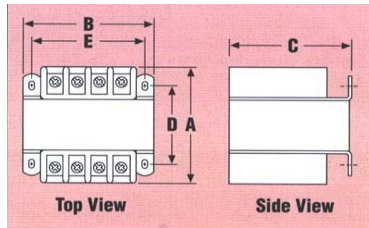

**DIMENSIONS: IMPERVITRAN
P/N BEGINNING "B"**

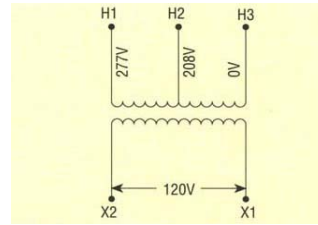

**CONNECTION DIAGRAM:
GROUP "F"**

CONTROL TRANSFORMERS:

All are UL Listed, CSA Certified and 50/60 Hz

GROUP "F"

CATALOG NUMBER	UPC #	OUTPUT		DIMENSIONS INCHES (MM)										MOUNTING SLOTS		APPROX. WEIGHT	
		VA	AMPS	A		B		C		D		E		IN	MM	LBS	KG
VOLTAGE:				IN	MM	IN	MM	IN	MM	IN	MM	IN	MM	IN	MM		
PRI: 208/277																	
SEC: 120																	
B050MQ15XK	003987	50	0.42	3 1/8	79	3	76	2 9/16	65	2	51	2 1/2	64	.203 X 460	5 X 12	2.6	1.2
B050MQ15RK	003970							3 15/16	99								
B075MQ15XK	005998	75	0.63	3 5/8	92	3	76	2 9/16	65	2 1/2	64	2 1/2	64	.203 X 460	5 X 12	3.5	1.6
B075MQ15RK	005981							3 15/16	99								
B100MQ15XK	008623	100	0.83	3 7/16	87	3 3/8	86	2 7/8	73	2 3/8	60	2 13/16	71	.203 X 460	5 X 12	4.2	1.9
B100MQ15RK	008609							4 1/4	107								
B150MQ15XKF	048667	150	1.25	4	102	3 3/4	95	3 3/16	81	2 7/8	73	3 1/8	79	.203 X 460	5 X 12	6.0	2.7
B150MQ15RKF	059366							4 9/16	115								
B200MQ15XKF	048674	200	1.67	4	102	4 1/2	114	3 13/16	97	2 1/2	64	3 3/4	95	.203 X 460	5 X 12	7.0	3.2
B200MQ15RKF	059373							5 3/16	131								
B250MQ15XKF	048681	250	2.08	4 3/8	111	4 1/2	114	3 13/16	97	2 7/8	73	3 3/4	95	.203 X 460	5 X 12	10.0	4.5
B250MQ15RKF	059380							5 3/16	131								
B300MQ15XKF	048698	300	2.50	4 3/4	121	4 1/2	114	3 13/16	97	3 1/4	83	3 3/4	95	.203 X 460	5 X 12	12.0	5.5
B300MQ15RKF	059397							5 3/16	131								
B350MQ15XKF	048704	350	2.92	5 1/4	133	4 1/2	114	3 13/16	97	3 3/4	95	3 3/4	95	.203 X 460	5 X 12	13.0	5.9
B350MQ15RKF	059403							5 3/16	131								
B500MQ15XKF	048711	500	4.17	5 3/8	137	5 1/4	133	4 3/4	121	4 1/8	105	4 3/8	111	.313 X 1.063	8 X 27	16.0	7.3
B500MQ15RKF	059410							6 1/8	155								
B750MQ15XKF	048728	750	6.25	7	178	5 1/4	133	4 3/4	121	5 3/4	146	4 3/8	111	.313 X 1.063	8 X 27	18.0	8.2
B750MQ15RKF	058925							6 1/8	155								

NOTE: RK, RKF SUFFIX = PRIMARY CL "CC" FUSE BLOCK ATTACHED. DIMENSION "C" CHANGE NOTED.

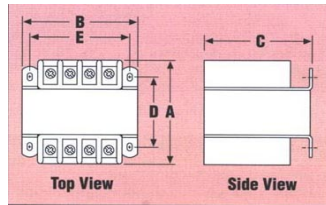

**DIMENSIONS: IMPERVITRAN
P/N BEGINNING "B"**

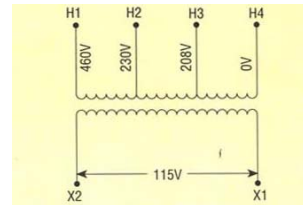

**CONNECTION DIAGRAM:
GROUP "G"**

CONTROL TRANSFORMERS:

All are UL Listed, CSA Certified and 50/60 Hz

GROUP "G"

CATALOG NUMBER	UPC # 784550	OUTPUT		DIMENSIONS INCHES (MM)								MOUNTING SLOTS		APPROX. WEIGHT			
		VA	AMPS	A		B		C		D		E		IN	MM	LBS	KG
VOLTAGE:																	
PRI: 208/230/460																	
SEC: 115																	
B050MBT13XK	003857	50	0.43	3 3/8	86	3	76	2 9/16	65	2 1/8	56	2 1/2	64	.203 X .460	5 X 12	2.8	1.3
B050MBT13RK	003840							3 15/16	99								
B075MBT13XK	005929	75	0.65	3 1/2	89	3 3/8	86	2 7/8	73	2 7/16	61	2 13/16	71	.203 X .460	5 X 12	4.6	2.1
B075MBT13RK	005912							4 1/4	107								
B100MBT13XK	008500	100	0.87	3 13/16	97	3 3/8	86	2 7/8	73	2 5/8	67	2 13/16	71	.203 X .460	5 X 12	4.9	2.2
B100MBT13RK	008494							4 1/4	107								
B150MBT13XKF	048766	150	1.30	4	102	3 3/4	95	3 3/16	81	3	76	3 1/8	79	.203 X .460	5 X 12	5.5	2.5
B150MBT13RKF	059755							4 9/16	115								
B200MBT13XKF	048773	200	1.74	4	102	4 1/2	114	3 7/8	99	2 13/16	71	3 3/4	95	.203 X .460	5 X 12	7.0	3.2
B200MBT13RKF	055429							5 1/4	133								
B250MBT13XKF	048780	250	2.17	4 3/8	111	4 1/2	114	3 7/8	99	3 3/16	81	3 3/4	95	.203 X .460	5 X 12	9.0	4.1
B250MBT13RKF	059762							5 1/4	133								
B300MBT13XKF	048797	300	2.61	4 3/8	111	4 1/2	114	3 13/16	97	3 3/16	81	3 3/4	95	.203 X .460	5 X 12	11.0	5.0
B300MBT13RKF	059779							5 3/16	131								
B350MBT13XKF	048803	350	3.04	5 3/4	146	4 1/2	114	3 7/8	99	4 3/4	121	3 3/4	95	.203 X .844	5 X 21.4	13.0	5.9
B350MBT13RKF	059786							5 1/4	133								
B500MBT13XKF	048810	500	4.35	5 1/8	130	5 1/4	133	4 1/2	114	4 3/8	111	4 3/8	111	.313 X 1.063	8 X 27	15.0	6.8
B500MBT13RKF	059793							5 7/8	148								
B750MBT13XKF	048827	750	6.52	7 3/16	183	5 1/4	133	4 1/2	114	5 7/8	149	4 3/8	111	.313 X 1.063	8 X 27	28.0	12.7
B750MBT13RKF	055177							5 7/8	148								
B1K0MBT13XKF	058673	1000	8.70	7	178	6 3/8	162	5 7/16	138	5 1/16	129	5 5/16	135	.313 X 1.249	8 X 32	29.8	13.6
B1K0MBT13RKF	059809							6 13/16	172								
B1K5MBT13XKH	058680	1500	13.04	7 13/16	198	6 3/4	171	5 3/4	146	4 1/4	108	6 3/16	156	.313 X .437	8 X 11	39.0	17.6
B1K5MBT13RKH	059816							7 1/8	180								
B2K0MBT13XKH	058222	2000	17.39	8 1/8	207	6 3/4	171	5 3/4	146	5 1/2	140	6 1/8	156	.281 X .375	7 X 9.5	42.0	19.0
B2K0MBT13RKH	059823							7 1/8	180								
B3K0MBT13XXH	058796	3000	26.09	8 1/2	216	9	229	7 1/2	191	5 11/16	145	7 3/4	191	.44 X .91	11 X 23	64.5	29.2
B5K0MBT13XXH	058802	5000	43.48	10 3/8	264	9	229	10 3/16	259	7 9/16	192	6 1/2	165	.44 X .91	11 X 23	97.0	44.0

NOTE: RK, RKF, RKH SUFFIX = PRIMARY CL "CC" FUSE BLOCK ATTACHED. DIMENSION "C" CHANGE NOTED.
XXH HAS NO PROVISION FOR SECONDARY FUSING.

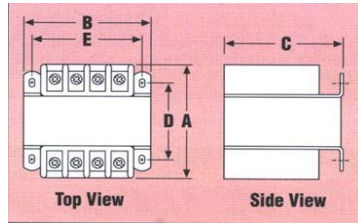

**DIMENSIONS: IMPERVITRAN
P/N BEGINNING "B"**

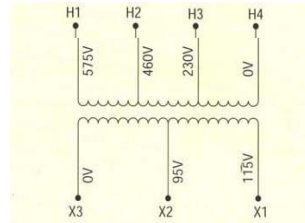

**CONNECTION DIAGRAM:
GROUP "H"**

CONTROL TRANSFORMERS:

All are UL Listed, CSA Certified and 50/60 Hz

GROUP "H"

CATALOG NUMBER	UPC # 784550	OUTPUT		DIMENSIONS INCHES (MM)										MOUNTING SLOTS		APPROX. WEIGHT			
		VA	AMPS	A		B		C		D		E		IN	MM	LBS	KG		
VOLTAGE:				IN	MM	IN	MM	IN	MM	IN	MM	IN	MM	IN	MM	IN	MM	LBS	KG
PRI: 230/460/575 SEC: 95/115																			
B1K0BTWZ37XKH	058628	1000	10.53/8/70	7	178	6 3/8	162	5 7/16	138	5 1/16	129	5 5/16	135	.313 x 1.250	8 x 32	27.9	12.6		
B1K0BTWZ37RKH	059427							6 13/16	172										
B1K5BTWZ37XKH	058666	1500	15.79/13.04	7 3/4	197	6 3/4	171	5 3/4	146	5 1/4	133	6 1/8	158	.313 x .625	8 x 16	43.1	19.5		
B1K5BTWZ37RKH	059434							7 1/8	180										
B2K0BTWZ37XKH	057935	2000	21.05/17.39	7 5/8	194	9	229	7 5/8	193	4 13/16	122	7 1/2	191	.440 x .910	11 x 23	56.0	25.3		
B2K0BTWZ37RKH	059458							9	227										
B3K0BTWZ37XXH	058772	3000	31.58/26.09	8 3/4	222	9	229	7 5/8	193	5 15/16	151	7 1/2	191	.440 x .910	11 x 23	76.2	34.5		
B5K0BTWZ37XXH	058789	5000	52.63/43.48	10	254	9	229	7 5/8	193	8 3/16	208	7 1/2	191	.440 x .910	11 x 23	127.4	57.6		

NOTE: RKH SUFFIX = PRIMARY CL "CC" FUSE BLOCK ATTACHED. DIMENSION "C" CHANGE NOTED.
XXH SUFFIX HAS NO PROVISION FOR SECONDARY FUSING.

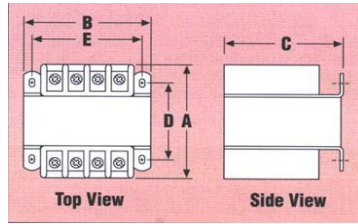

**DIMENSIONS: IMPERVITRAN
P/N BEGINNING "B"**

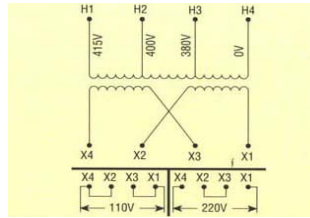

**CONNECTION DIAGRAM:
GROUP "I"**

**CONTROL TRANSFORMERS:
GROUP "I"**

All are UL Listed, CSA Certified and 50/60 Hz

CATALOG NUMBER	UPC # 784550	OUTPUT		DIMENSIONS INCHES (MM)										MOUNTING SLOTS		APPROX. WEIGHT	
		VA	AMPS	A		B		C		D		E		IN	MM	LBS	KG
VOLTAGE:				IN	MM	IN	MM	IN	MM	IN	MM	IN	MM	IN	MM		
PRI: 380/400/415 SEC: 110x220																	
B050RFD34XJ	004267	50	0.46/0.23	3 1/8	79	3	76	2 9/16	65	2	51	2 1/2	64	.203 X .460	5 X 12	3.0	1.4
B050RFD34RJ	004250							3 15/16	99								
B075RFD34XJ	006131	75	0.68/0.34	3 5/8	92	3	76	2 9/16	65	2 1/2	64	2 1/2	64	.203 X .460	5 X 12	4.0	1.8
B075RFD34RJ	006124							3 15/16	99								
B100RFD34XJ	008838	100	0.91/0.46	3 7/16	91	3 3/8	86	2 7/8	73	2 9/16	65	2 13/16	71	.203 X .460	5 X 12	5.2	2.4
B100RFD34RJ	008821							4 1/4	107								
B150RFD34XJF	048971	150	1.37/0.69	3 5/8	92	3 3/4	95	3 3/16	81	2 13/16	71	3 1/8	79	.203 X .460	5 X 12	6.0	2.7
B150RFD34RJF	059489							4 9/16	115								
B200RFD34XJF	048988	200	1.82/0.91	3 3/4	95	4 1/2	114	3 7/8	99	2 7/16	62	3 3/4	95	.203 X .460	5 X 12	8.0	3.6
B200RFD34RJF	059496							5 1/4	133								
B250RFD34XJF	048995	250	2.28/1.14	4	102	4 1/2	114	3 7/8	99	2 13/16	71	3 3/4	95	.203 X .460	5 X 12	10.0	4.5
B250RFD34RJF	059502							5 1/4	133								
B300RFD34XJF	049008	300	2.72/1.36	4 3/8	111	4 1/2	114	3 7/8	99	3 3/16	81	3 3/4	95	.203 X .460	5 X 12	12.0	5.5
B300RFD34RJF	059519							5 1/4	133								
B350RFD34XJF	049015	350	3.18/1.59	4 3/4	121	4 1/2	114	3 7/8	99	3 3/4	95	3 3/4	95	.203 X .460	5 X 12	14.0	6.4
B350RFD34RJF	059526							5 1/4	133								
B500RFD34XJF	049022	500	4.55/2.27	5 1/8	130	5 1/4	133	4 1/2	114	3 7/8	99	4 3/8	111	.313 X 1.063	8 X 27	16.0	7.3
B500RFD34RJF	059533							5 7/8	148								
B750RFD34XJF	049039	750	6.82/3.41	6 5/8	168	5 1/4	133	4 1/2	114	5 3/8	137	4 3/8	111	.313 X 1.063	8 X 27	18.0	8.2
B750RFD34RJF	059540							5 7/8	148								

NOTE: RJ, RJF SUFFIX = PRIMARY CL "CC" FUSE BLOCK ATTACHED. DIMENSION "C" CHANGE NOTED.

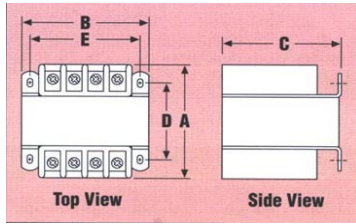

**DIMENSIONS: IMPERVITRAN
P/N BEGINNING "B"**

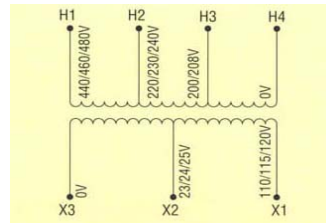

**CONNECTION DIAGRAM:
GROUP "J"**

**CONTROL TRANSFORMERS:
GROUP "J"**

All are UL Listed, CSA Certified and 50/60 Hz

CATALOG NUMBER	UPC # 784550	OUTPUT		DIMENSIONS INCHES (MM)										MOUNTING SLOTS		APPROX. WEIGHT						
		VA	AMPS	A		B		C		D		E		IN	MM	LBS	KG					
VOLTAGE:																						
PRI: 208/230/460																						
SEC: 24/115																						
B050MBT713XK	003901	50	2.08/0.44	3	1/2	83	3	76	2	9/16	65	2	3/16	56	2	1/2	64	.203 X .460	5 X 12	3.4	1.6	
B050MBT713RK	003888									3	15/16	99										
B075MBT713XK	005967	75	3.13/0.65	3	5/8	92	3	3/8	86	2	7/8	73	2	7/16	61	2	13/16	71	.203 X .460	5 X 12	4.8	2.2
B075MBT713RK	005943									4	1/4	107										
B100MBT713XK	008562	100	4.17/0.87	3	5/8	92	3	3/4	95	3	3/16	81	2	7/16	61	3	1/8	79	.203 X .460	5 X 12	5.9	2.7
B100MBT713RK	008531									4	9/16	115										
B150MBT713XKF	048117	150	6.25/1.30	4	1/4	108	3	3/4	95	3	3/16	81	3	3/16	81	3	1/8	79	.203 X .460	5 X 12	8.0	3.6
B150MBT713RKF	048155									4	9/16	115										
B200MBT713XKF	048148	200	8.33/1.74	4	1/4	108	4	1/2	114	3	7/8	99	3		76	3	3/4	95	.203 X .460	5 X 12	9.0	4.1
B200MBT713RKF	048162									5	1/4	133										
B250MBT713XKF	047929	250	10.42/2.17	4	3/4	121	4	1/2	114	3	7/8	99	3	3/4	95	3	3/4	95	.203 X .460	5 X 12	12.0	5.5
B250MBT713RKF	048209									5	1/4	133										
B300MBT713XKF	047967	300	12.50/2.61	5	3/16	132	5	1/4	133	4	1/2	114	3	7/8	99	4	3/8	111	.313 X 1.063	8 X 27	14.0	6.4
B300MBT713RKF	048124									5	7/8	148										
B350MBT713XKF	047905	350	14.58/3.04	5	3/16	132	5	1/4	133	4	1/2	114	3	7/8	99	4	3/8	111	.313 X 1.063	8 X 27	15.0	6.8
B350MBT713RKF	048216									5	7/8	148										
B500MBT713XKF	048193	500	20.84/4.35	6	11/16	170	5	1/4	133	4	1/2	114	5	3/8	137	4	3/8	111	.313 X 1.063	8 X 27	18.0	8.2
B500MBT713RKF	048261									5	7/8	148										

NOTE: RK, RKF SUFFIX = PRIMARY CL "CC" FUSE BLOCK ATTACHED. DIMENSION "C" CHANGE NOTED.

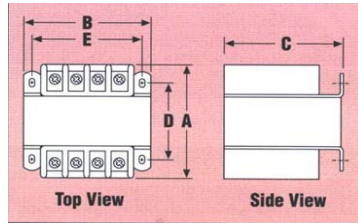

**DIMENSIONS: IMPERVITRAN
P/N BEGINNING "B"**

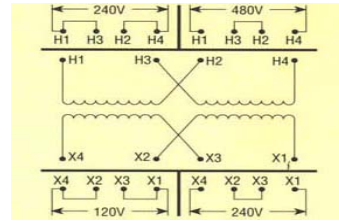

**CONNECTION DIAGRAM:
GROUP "K"**

**CONTROL TRANSFORMERS:
GROUP "K"**

All are UL Listed, CSA Certified and 50/60 Hz

CATALOG NUMBER	UPC # 784550	OUTPUT		DIMENSIONS INCHES (MM)										MOUNTING SLOTS		APPROX. WEIGHT	
		VA	AMPS	A		B		C		D		E		IN	MM	LBS	KG
VOLTAGE:				IN	MM	IN	MM	IN	MM	IN	MM	IN	MM	IN	MM		
PRI: 240x480 SEC: 120x240																	
B050PU1519JJ	004014	50	0.42/0.21	3 1/8	79	3	76	2 9/16	65	2	51	2 1/2	64	.203 X .460	5 X 12	2.6	1.2
B050PU1519RR	004021							3 15/16	99								
B075PU1519JJ	006001	75	0.63/0.31	3 5/8	92	3	76	2 9/16	65	2 1/2	64	2 1/2	64	.203 X .460	5 X 12	3.5	1.6
B075PU1519RR	006018							3 15/16	99								
B100PU1519JJ	008661	100	0.83/0.42	3 1/2	89	3 3/8	86	2 7/8	73	2 3/8	60	2 13/16	71	.203 X .460	5 X 12	4.2	1.9
B100PU1519RR	008678							4 1/4	107								
B150PU1519JJF	049077	150	1.25/0.63	3 5/8	92	3 3/4	95	3 3/16	81	2 13/16	71	3 1/8	79	.203 X .460	5 X 12	6.0	2.7
B150PU1519RRF	059564							4 9/16	115								
B200PU1519JJF	049084	200	1.67/0.83	3 3/4	95	4 1/2	114	3 7/8	99	2 13/16	71	3 3/4	95	.203 X .460	5 X 12	8.0	3.6
B200PU1519RRF	059571							5 1/4	133								
B250PU1519JJF	049091	250	2.08/1.04	4	102	4 1/2	114	3 7/8	99	2 13/16	71	3 3/4	95	.203 X .460	5 X 12	10.0	4.6
B250PU1519RRF	059588							5 1/4	133								
B300PU1519JJF	049107	300	2.50/1.25	4 3/8	111	4 1/2	114	3 7/8	99	3 7/16	87	3 3/4	95	.203 X .460	5 X 12	12.0	5.5
B300PU1519RRF	059595							5 1/4	133								
B350PU1519JJF	049114	350	2.92/1.46	4 3/4	121	4 1/2	114	3 7/8	99	3 3/4	95	3 3/4	95	.203 X .460	5 X 12	12.0	5.5
B350PU1519RRF	059601							5 1/4	133								
B500PU1519JJF	049121	500	4.17/2.08	5 1/8	130	5 1/4	133	4 1/2	114	3 7/8	99	4 3/8	111	.313 X 1.063	8 X 27	16.0	7.3
B500PU1519RRF	059618							5 7/8	148								
B750PU1519JJF	049138	750	6.25/3.12	6 5/8	168	5 1/4	133	4 1/2	114	5 3/8	137	4 3/8	111	.313 X 1.063	8 X 27	18.0	8.2
B750PU1519RRF	059625							5 7/8	148								

NOTE: RR, RRF SUFFIX = PRIMARY CL "CC" FUSE BLOCK ATTACHED. DIMENSION "C" CHANGE NOTED.

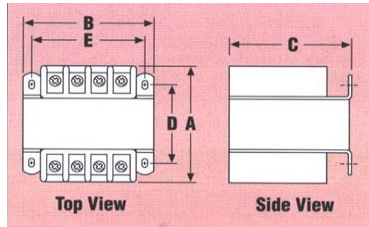

**DIMENSIONS: IMPERVITRAN
P/N BEGINNING "B"**

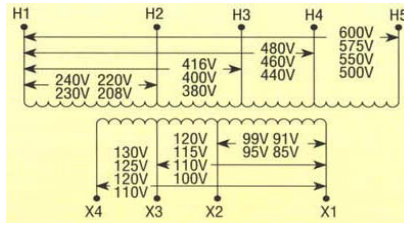

**CONNECTION DIAGRAM:
GROUP "L"**

CONTROL TRANSFORMERS:

All are UL Listed, CSA Certified and 50/60 Hz

GROUP "L"

CATALOG NUMBER	UPC # 784550	OUTPUT		DIMENSIONS INCHES (MM)										MOUNTING SLOTS		APPROX. WEIGHT	
		VA	AMPS	A		B		C		D		E		IN	MM	LBS	KG
VOLTAGE:				IN	MM	IN	MM	IN	MM	IN	MM	IN	MM	IN	MM		
PRI: 208-600																	
SEC: 85-130																	
B050-0482-1	029499	50	0.38	3 3/8	86	3 3/8	86	2 7/8	73	2 7/16	61	2 13/16	71	.203 X .460	5 X 12	4.0	1.8
B050-0482-8	020505							4 1/4	107								
B100-0483-1	029789	100	0.77	4	101	3 3/4	95	3 1/8	79	3	78	3 1/8	79	.203 X .460	5 X 12	6.6	3.0
B100-0483-8	029796							4 1/2	113								
B150-0484-1F	057270	150	1.15	3 3/4	95	4 1/2	114	3 7/8	99	2 13/16	71	3 3/4	95	.203 X .460	5 X 12	8.7	3.9
B150-0484-8F	059649							5 1/4	133								
B250-0485-1F	053715	250	1.92	5 3/4	146	4 1/2	114	3 7/8	99	4 3/4	121	3 3/4	95	.203 X .844	5 X 21.4	11.4	5.2
B250-0485-8F	059656							5 1/4	133								
B350-0486-1F	058178	350	2.69	5 11/16	145	5 1/4	133	4 1/2	113	4 3/8	111	4 3/8	111	.313 X 1.063	8 X 27	13.6	6.2
B350-0486-8F	059663							5 7/8	147								
B500-0487-1F	058314	500	3.85	7 3/16	183	5 1/4	133	4 1/2	113	5 7/8	149	4 3/8	111	.313 X 1.063	8 X 27	17.4	7.9
B500-0487-8F	059670							5 7/8	147								
B750-0488-1F	058192	750	5.77	6 1/2	165	6 3/4	171	5 3/4	146	4 1/4	108	6 1/8	156	.313 X .750	8 X 19	27.5	12.4
B750-0488-8F	059694							7 1/8	180								

NOTE: -8, -8F SUFFIX = PRIMARY CL "CC" FUSE BLOCK ATTACHED. DIMENSION "C" CHANGE NOTED.

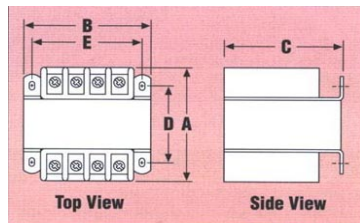

**DIMENSIONS: IMPERVITRAN
P/N BEGINNING "B"**

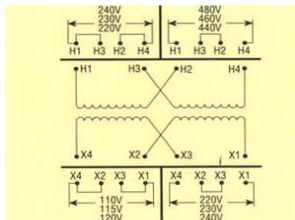

**CONNECTION DIAGRAM:
GROUP "M"**

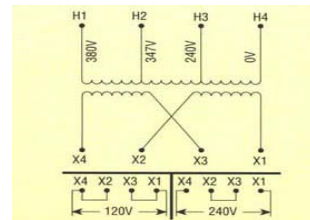

**CONNECTION DIAGRAM:
GROUP "N"**

CONTROL TRANSFORMERS:

All are UL Listed, CSA Certified and 50/60 Hz

GROUP "M"

CATALOG NUMBER	UPC # 784550	OUTPUT		DIMENSIONS INCHES (MM)										MOUNTING SLOTS		APPROX. WEIGHT		
		VA	AMPS	A		B		C		D		E		IN	MM	LBS	KG	
VOLTAGE:																		
PRI: 240x480, 230x460, 220x440																		
SEC: 120x240, 115x230, 110x220																		
B1K0-0500-3F	058260	1000	8.70/4.35	7	178	5 1/4	133	4 1/2	114	5 3/8	137	4 3/8	111	.313 X 1.063	8 X 27	26.3	11.9	
B1K5-0501-3F	058864	1500	13.04/6.52	7	178	6 3/4	171	5 3/4	146	4 1/4	108	6 1/8	156	.313 X .437	8 X 11	31.0	14.1	
B2K0-0502-3H	058284	2000	17.39/8.70	8 1/8	207	6 3/4	171	5 3/4	146	5 1/2	140	6 1/8	156	.281 X .375	7 X 9.5	40.0	18.1	
B3K0-0503-3H	058291	3000	26.09/13.04	8 1/8	207	9	229	7 1/2	191	5 1/4	133	7 1/2	191	.440 X .910	11 X 23	56.0	25.4	
B5K0-0504-3H	058307	5000	43.48/21.74	10	254	9	229	10 3/16	259	7 3/16	183	7 1/2	191	.440 X .910	11 X 23	85.4	38.7	

GROUP "N"

CATALOG NUMBER	UPC # 784550	OUTPUT		DIMENSIONS INCHES (MM)										MOUNTING SLOTS		APPROX. WEIGHT		
		VA	AMPS	A		B		C		D		E		IN	MM	LBS	KG	
VOLTAGE:																		
PRI: 240/347/380																		
SEC: 120x240																		
B1K0-0321-3F	058123	1000	8.33/4.17	7	178	6 3/8	162	5 7/16	138	5 1/16	129	5 5/16	135	.313 X 1.25	8 X 32	29.0	13.2	
B1K5-0322-3F	058871	1500	12.50/6.25	8 1/8	207	6 3/8	162	5 7/16	138	5 1/16	129	5 5/16	135	.313 X 1.25	8 X 32	33.3	15.1	
B2K0-0323-3H	058147	2000	16.67/8.33	8 7/8	226	6 3/4	171	5 3/4	146	6 1/4	159	6 1/8	156	.281 X .375	7 X 9.5	50.0	22.7	
B3K0-0324-3H	058154	3000	25.00/12.50	8 1/2	216	9	229	7 1/2	191	5 11/16	145	7 1/2	191	.440 X .910	11 X 23	74.0	33.6	
B5K0-0325-3H	058161	5000	41.67/20.83	10 3/8	264	9	229	7 1/2	191	7 9/16	192	7 1/2	191	.440 X .910	11 X 23	110.0	49.9	

CATALOG NUMBER	CONTROL TRANSFORMER ACCESSORIES		UPC #	APPROX. WEIGHT	
			784550	LBS	KG
	IP-20 SAFETOUCH™ COVERS				
TPTC-2001	10PACK 4TERM.		029369	1.0	0.5
TPTC-2002	10PACK 6TERM.		029376	1.0	0.5
TPTC-2006	10PACK UNIVERSAL PRI BLOCK		059090	1.0	0.5
FKTP-1001	PRIMARY CL "CC" FUSE KIT		026634	0.25	0.1
CL. "CC" PRI.	OPTIONAL FACTORY INSTALLED FUSE HOLDERS P/N SUFFIX = RB, RK, RX, RJ, RR RY, RG, RL, RN, RC, -8 *NON-REJECTION VERSION AVAILABLE ON ALL FACTORY INSTALLED PRIMARY FUSEBLOCK OPTIONS			N/A	
1/4 X 11/4 SEC.	P/N SUFFIX = JQ, XQ			N/A	
9/16 X 2 SEC.	P/N SUFFIX = JM, XM			N/A	
514-1660	BULK FUSE CLIPS (2 NECESSARY) 1/4 X 11/4		N/A	N/A	
514-1650	BULK JUMPERS J-2		N/A	N/A	
514-1652	J-3		N/A	N/A	

TRANSFORMER ACCESSORY INTERCHANGE MATRIX

STANDARD SUFFIX		DUAL PRIMARY FUSED SUFFIX
JK, JKF, JKH	>>	RB, RBF, RBH
XX, XKF, XKH	>>	RK, RKF, RKH
XX, XXF, XXH	>>	RX, RXF, RXH
XJ, XJF, XJH	>>	RJ, RJF, RJH
JJ, JJF, JJH	>>	RR, RRF, RRH
JM, JMF, JMH	>>	RY, RYF, RYH
XM, JMF, JMH	>>	RG, RGF, RGH
JQ, JQF, JQH	>>	RL RLF, RLH
XQ, XQF, XQH	>>	RN, RNF, RNH
JX, JXF, JXH	>>	RC, RCF, RCH
-1, -1F, -1H	>>	-8, -8F, -8H

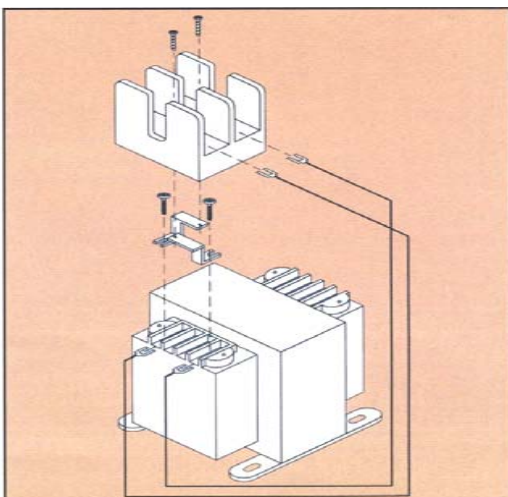
PRIMARY FUSE KIT # FKTP-1001

In addition to factory installed primary fusing capability Micron offers a primary fuse kit for ImperviTRAN and ValuTRAN intended for field installation. The primary fuse kit includes a 2-pole Class "CC" fuse block, instructions and all associated mounting hardware. Additionally, this fuse block will fit most competitive units. To order this kit, use catalog number **FKTP-1001**. The primary fuse kit, when installed, will add a maximum of 11/16" to the transformer "A" dimension and 1-15/16" to the "C" dimension. Installed as indicated.

1. Loosen two outer screws on primary side of transformer. On 6 position shell leave 2 spaces open between brackets.
2. Capture mounting brackets and necessary leads under terminal screws and tighten.
3. Affix fuse block to mounting bracket with supplied screws.

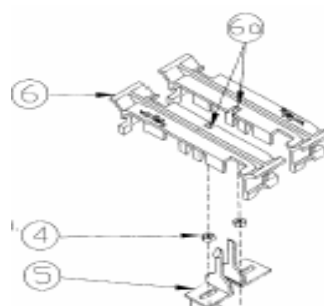
IP-20 COVER KIT # TPTC-2006

4. Remove two nuts holding primary fuse block to transformer. On FKTP-1001 kits, perform step #5 prior to affixing block to brackets.
5. Install retaining clips in base of fuse block. Secure with nuts or screws as appropriate.
- 6, 6a. Install fuse in cover and snap cover in place. When installed cover cannot be removed without releasing tab from detent (6a). A tip of a pen will suffice.

GLOBALTRAN ACCESSORIES

A number of fusing accessories are available for the GlobalTRAN product line. Please contact Micron with your design requirements.

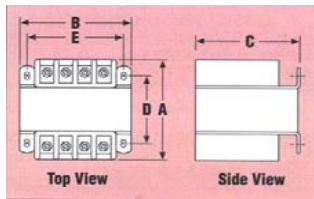

**DIMENSIONS: IMPERVITRAN
P/N BEGINNING "B"**

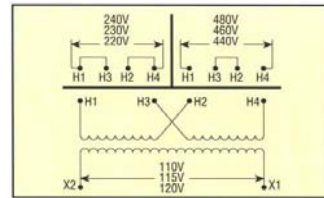

**CONNECTION DIAGRAM:
GROUP "A"**

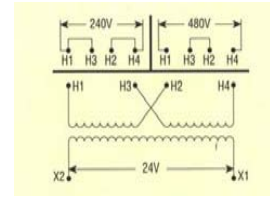

**CONNECTION DIAGRAM:
GROUP "B"**

**GLOBALTRAN:
GROUP "A"**

All meet EN 61558-2-2, are UL Listed, CSA Certified and 50/60 Hz

CATALOG NUMBER	UPC # 784550	OUTPUT		DIMENSIONS INCHES (MM)										MOUNTING SLOTS		APPROX. WEIGHT						
		VA	AMPS	A		B		C		D		E		IN	MM	LBS	KG					
VOLTAGE:				IN	MM	IN	MM	IN	MM	IN	MM	IN	MM	IN	MM	IN	MM	LBS	KG			
PRI: 220x440, 230x460, 240x480																						
SEC: 110/115/120																						
B050-2001-GA	054200	50	0.43	3	3/8	86	3	76	3	76	2	7/16	61	2	1/2	64	.203 X .460	5 X 12	3.4	1.6		
B075-2002-GA	054231	75	0.65	3	3/8	86	3	3/8	86	3	1/4	83	2	7/16	61	2	13/16	71	.203 X .460	5 X 12	4.8	2.2
B100-2003-GA	054224	100	0.87	3	3/8	86	3	3/4	95	3	1/2	89	2	7/16	61	3	1/8	79	.203 X .460	5 X 12	5.9	2.7
B150-2004-GAF	054248	150	1.30	3	3/4	95	4	1/2	114	4		102	2	7/16	61	3	3/4	95	.203 X .460	5 X 12	8.5	3.8
B200-2005-GAF	054255	200	1.74	3	3/4	95	4	1/2	114	4		102	2	13/16	71	3	3/4	95	.203 X .460	5 X 12	10.0	4.5
B250-2006-GAF	054262	250	2.17	4		102	4	1/2	114	4		102	3	3/16	81	3	3/4	95	.203 X .460	5 X 12	11.0	5.0
B300-2007-GAF	054279	300	2.61	4	3/8	111	4	1/2	114	4		102	3	3/4	95	3	3/4	95	.203 X .460	5 X 12	13.0	5.9
B350-2008-GAF	054286	350	3.04	4	7/8	124	5	1/4	133	4	1/2	114	3	3/8	86	4	3/8	111	.313 X 1.06	8 X 27	15.0	6.8
B500-2009-GAF	054293	500	4.35	5	1/8	130	5	1/4	133	4	1/2	114	4	3/8	111	4	3/8	111	.313 X 1.06	8 X 27	20.0	9.0
B750-2010-GAF	054309	750	6.52	7		178	5	1/4	133	4	1/2	114	5	7/8	149	4	3/8	111	.313 X 1.06	8 X 27	29.8	13.5
B1K0-2008-GAH	054903	1000	8.70	6	5/8	168	6	3/8	162	5	1/2	140	3	3/4	95	5	5/16	135	.313 X 1.25	8 X 31	35.0	15.8
B1K5-2009-GAH	054910	1500	13.04	7	5/16	186	6	3/4	172	6		152	5		127	6	1/8	156	.313 X .906	8 X 23	40.0	18.1
B2K0-2010-GAH	054927	2000	17.39	8	1/8	203	6	3/4	172	6		152	5	1/4	133	6	1/8	156	.281 X .562	7 X 25	45.0	20.4
B3K0-2011-GAH	056518	3000	26.09	8	1/16	202	9		225	8		200	5	1/4	133	7	1/2	191	.440 X .910	11 X 23	65.2	29.5
B5K0-2012-GAH	056525	5000	45.45	10		250	9		225	8		200	7	3/16	183	7	1/2	191	.440 X .910	11 X 23	104.8	47.42

GROUP "B"

CATALOG NUMBER	UPC # 784550	OUTPUT		DIMENSIONS INCHES (MM)										MOUNTING SLOTS		APPROX. WEIGHT						
		VA	AMPS	A		B		C		D		E		IN	MM	LBS	KG					
VOLTAGE:				IN	MM	IN	MM	IN	MM	IN	MM	IN	MM	IN	MM	IN	MM	LBS	KG			
PRI: 240x480																						
SEC: 24																						
B050-2011-GA	055542	50	2.08	3	3/8	86	3		76	3		76	2	3/16	56	2	1/2	64	.203 X .460	5 X 12	3.4	1.5
B075-2012-GA	055559	75	3.13	3	3/8	86	3	3/8	86	3	1/4	83	2	3/16	56	2	13/16	71	.203 X .460	5 X 12	4.2	1.9
B100-2013-GA	055566	100	4.17	3	3/8	86	3	3/4	95	3	1/2	89	2	7/16	61	3	1/8	80	.203 X .460	5 X 12	5.9	2.7
B150-2014-GAF	055757	150	6.25	4		102	4	1/2	114	4		102	2	7/16	62	3	3/4	95	.203 X .460	5 X 12	8.5	3.8
B200-2015-GAF	055764	200	8.33	3	3/4	95	4	1/2	114	4		102	2	13/16	71	3	3/4	95	.203 X .460	5 X 12	10.0	4.5
B250-2016-GAF	055771	250	10.42	4		102	4	1/2	114	4		102	3	3/16	81	3	3/4	95	.203 X .460	5 X 12	11.0	5.0
B300-2017-GAF	055788	300	12.50	4	3/8	111	4	1/2	114	4		102	3	3/4	95	3	3/4	95	.203 X .460	5 X 12	13.2	6.0
B350-2018-GAF	055795	350	14.58	4	1/2	114	5	1/4	133	4	1/2	114	3	3/8	86	4	3/8	111	.313 X 1.06	8 X 27	14.9	6.7
B500-2019-GAF	055801	500	20.83	5	1/8	130	5	1/4	133	4	1/2	114	3	7/8	99	4	3/8	111	.313 X 1.06	8 X 27	19.2	8.9
B750-2020-GAF	055818	750	31.25	7		178	5	1/4	133	5		127	5	3/8	137	4	3/8	111	.313 X 1.06	8 X 27	28.1	11.9
B1K0-2028-GAF	056921	1000	41.67	7		178	6	3/8	162	6		152	3	3/4	95	5	5/16	135	.313 X 1.25	8 X 32	30	13.6

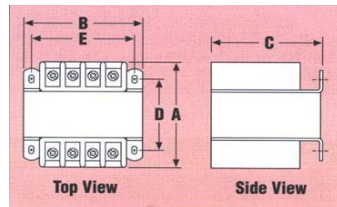

**DIMENSIONS: IMPERVITRAN
P/N BEGINNING "B"**

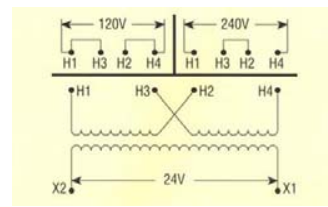

**CONNECTION DIAGRAM:
GROUP "C"**

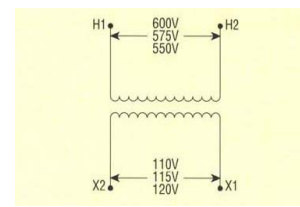

**CONNECTION DIAGRAM:
GROUP "D"**

All meet EN 61558-2-2, are UL Listed, CSA Certified and 50/60 Hz

GLOBALTRAN: GROUP "C"		OUTPUT		DIMENSIONS INCHES (MM)										MOUNTING SLOTS		APPROX. WEIGHT	
CATALOG NUMBER	UPC # 784550	VA	AMPS	A		B		C		D		E		IN	MM	LBS	KG
VOLTAGE: PRI: 120x240 SEC: 24				IN	MM	IN	MM	IN	MM	IN	MM	IN	MM	IN	MM		
B050-2021-GA	055481	50	2.08	3 3/8	86	3	76	3	76	2 3/16	55	2 1/2	64	.203 X .460	5 X 12	3.4	1.5
B075-2022-GA	055580	75	3.13	3 3/8	86	3 3/8	86	3 1/4	83	2 3/16	56	2 13/16	71	.203 X .460	5 X 12	4.2	1.9
B100-2023-GA	055597	100	4.17	3 3/8	86	3 3/4	95	3 1/2	89	2 7/16	61	3 1/8	79	.203 X .460	5 X 12	5.9	2.7
B150-2024-GAF	055825	150	6.25	3 3/4	95	4 1/2	114	4	102	2 7/16	61	3 3/4	95	.203 X .460	5 X 12	8.5	3.8
B200-2025-GAF	055832	200	8.33	3 3/4	95	4 1/2	114	4	102	2 13/16	70	3 3/4	95	.203 X .460	5 X 12	10.0	4.5
B250-2026-GAF	055849	250	10.42	4	102	4 1/2	114	4	102	3 3/16	81	3 3/4	95	.203 X .460	5 X 12	11.0	5.0
B300-2027-GAF	55856	300	12.50	4 3/8	111	4 1/2	114	4	102	3 3/4	95	3 3/4	95	.203 X .460	5 X 12	13.2	6.0
B350-2028-GAF	55863	350	14.58	4 1/2	114	5 1/4	133	4 1/2	114	3 3/8	86	4 3/8	111	.313 X 1.06	8 X 27	14.9	6.7
B500-2029-GAF	55870	500	20.83	5 1/8	130	5 1/4	133	4 1/2	114	3 7/8	99	4 3/8	111	.313 X 1.06	8 X 27	19.2	8.7
B750-2030-GAF	55887	750	31.25	7	178	5 1/4	133	4 1/2	114	5 7/8	149	4 3/8	111	.313 X 1.06	8 X 27	29.8	13.5
B1K0-2048-GAF	56938	1000	41.67	7	178	6 3/8	162	6	152	3 3/4	95	5 5/16	135	.313 X 1.25	8 X 32	31.0	14.0

GROUP "D"		OUTPUT		DIMENSIONS INCHES (MM)										MOUNTING SLOTS		APPROX. WEIGHT	
CATALOG NUMBER	UPC # 784550	VA	AMPS	A		B		C		D		E		IN	MM	LBS	KG
VOLTAGE: PRI: 550/575/600 SEC: 110/115/120				IN	MM	IN	MM	IN	MM	IN	MM	IN	MM	IN	MM		
B050-2041-GA	055610	50	0.43	3 3/8	86	3	76	3	76	2 7/16	61	2 1/2	64	.203 X .460	5 X 12	3.4	1.5
B075-2042-GA	055627	75	0.65	3 3/8	86	3 3/8	86	3 1/4	83	2 7/16	61	2 13/16	71	.203 X .460	5 X 12	4.8	2.2
B100-2043-GA	055634	100	0.87	3 3/8	86	3 3/4	95	3 1/2	89	2 7/16	61	3 1/8	80	.203 X .460	5 X 12	5.9	2.7
B150-2044-GAF	055894	150	1.30	3 3/4	95	4 1/2	114	4	102	2 7/16	61	3 3/4	95	.203 X .460	5 X 12	8.5	3.8
B200-2045-GAF	055900	200	1.74	3 3/4	95	4 1/2	114	4	102	3	76	3 3/4	95	.203 X .460	5 X 12	10.0	4.5
B250-2046-GAF	055917	250	2.17	4	102	4 1/2	114	4	102	3 3/16	81	3 3/4	95	.203 X .460	5 X 12	11.0	5.0
B300-2047-GAF	055924	300	2.61	4 3/8	111	4 1/2	114	4	102	3 3/4	95	3 3/4	95	.203 X .460	5 X 12	13.0	5.9
B350-2048-GAF	055931	350	3.04	4 1/2	114	5 1/4	133	4 1/2	114	3 3/8	86	4 3/8	111	.313 X 1.06	8 X 27	15.0	6.8
B500-2049-GAF	055948	500	4.35	5 1/8	130	5 1/4	133	4 1/2	114	4 3/8	111	4 3/8	111	.313 X 1.06	8 X 27	20.0	9.0
B750-2050-GAF	055955	750	6.52	7	178	5 1/4	133	4 1/2	114	5 3/8	137	4 3/8	111	.313 X 1.06	8 X 27	28.0	12.7

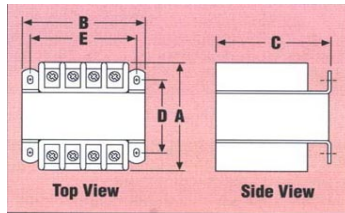

**DIMENSIONS: IMPERVITRAN
P/N BEGINNING "B"**

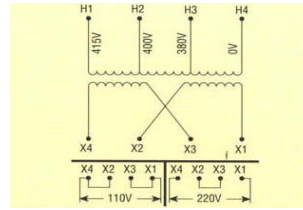

**CONNECTION DIAGRAM:
GROUP "E"**

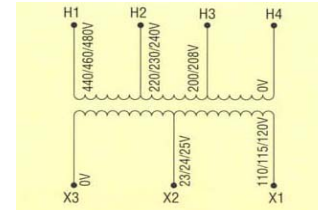

**CONNECTION DIAGRAM:
GROUP "F"**

All meet EN 61558-2-2, are UL Listed, CSA Certified and 50/60 Hz

GLOBALTRAN: GROUP "E"		OUTPUT		DIMENSIONS INCHES (MM)										MOUNTING SLOTS		APPROX. WEIGHT				
CATALOG NUMBER	UPC # 784550	VA	AMPS	A		B		C		D		E		IN	MM	LBS	KG			
VOLTAGE:		IN	MM	IN	MM	IN	MM	IN	MM	IN	MM	IN	MM	IN	MM					
PRI: 380/400/415 SEC: 110x220																				
B050-2061-GA	054743	50	.46/.23	3	3/8	86	3	76	3	76	2	7/16	61	2	1/2	64	.203 X .460	5 X 12	3.4	1.5
B075-2062-GA	054750	75	.68/.34	3	3/8	86	3	86	3	89	2	7/16	61	2	13/16	71	.203 X .460	5 X 12	4.8	2.2
B100-2063-GA	054767	100	.91/.46	3	3/8	86	3	95	3	89	2	7/16	61	3	1/8	79	.203 X .460	5 X 12	5.9	2.7
B150-2064-GAF	054774	150	1.37/.69	3	3/4	95	4	114	4	102	2	7/16	61	3	3/4	95	.203 X .460	5 X 12	8.5	3.8
B200-2065-GAF	054781	200	1.82/.91	3	3/4	95	4	114	4	102	3		76	3	3/4	95	.203 X .460	5 X 12	10.0	4.5
B250-2066-GAF	054804	250	2.28/1.14	4		102	4	114	4	102	3	3/16	81	3	3/4	95	.203 X .744	5 X 19	11.0	5.0
B300-2067-GAF	054811	300	2.72/1.36	4	3/8	111	4	114	4	102	3	3/4	95	3	3/4	95	.203 X .460	5 X 12	13.0	5.9
B350-2068-GAF	054835	350	3.18/1.59	4	3/4	121	4	114	4	102	3	3/4	95	3	3/4	95	.203 X .460	5 X 12	15.0	6.8
B500-2069-GAF	054842	500	4.55/2.27	5	1/8	130	5	133	4	114	4	3/8	111	4	3/8	111	.313 X 1.063	8 X 27	20.0	9.0
B750-2070-GAF	054859	750	6.82/3.41	7		178	5	133	4	114	5	7/8	149	4	3/8	111	.313 X 1.063	8 X 27	27.0	12.2

GROUP "F"		OUTPUT		DIMENSIONS INCHES (MM)										MOUNTING SLOTS		APPROX. WEIGHT				
CATALOG NUMBER	UPC # 784550	VA	AMPS	A		B		C		D		E		IN	MM	LBS	KG			
VOLTAGE:		IN	MM	IN	MM	IN	MM	IN	MM	IN	MM	IN	MM	IN	MM					
PRI: 208/230/460 SEC: 24/115																				
B050-2101-GA	055641	50	2.08/.44	3	3/8	86	3	86	3	83	2	1/4	56	2	13/16	71	.203 X .460	5 X 12	4.2	1.9
B075-2102-GA	055658	75	3.13/.65	3	3/8	86	3	95	3	89	2	7/16	61	3	1/8	79	.203 X .460	5 X 12	5.9	2.7
B100-2103-GA	055665	100	4.17/.87	3	5/8	92	3	95	3	89	3	3/16	81	3	1/8	79	.203 X .460	5 X 12	7.9	3.6
B150-2104-GAF	055962	150	6.25/1.3	3	3/4	95	4	114	4	102	2	13/16	71	3	3/4	95	.203 X .460	5 X 12	10.0	4.5
B200-2105-GAF	055979	200	8.33/1.74	7	3/8	111	4	114	4	102	3	7/16	87	3	3/4	95	.203 X .460	5 X 12	12.8	5.8
B250-2106-GAF	055986	250	10.42/2.17	4	3/4	121	4	114	4	102	3	3/4	95	3	3/4	95	.203 X .844	5 X 21	14.0	6.3
B300-2107-GAF	55993	300	12.50/2.61	4	7/8	124	5	133	4	114	3	7/8	99	4	3/8	111	.313 X 1.06	8 X 27	16.8	7.6
B350-2108-GAF	56013	350	14.58/3.04	4	7/8	124	5	133	4	114	3	7/8	99	4	3/8	111	.313 X 1.06	8 X 27	19.2	8.7
B500-2109-GAF	56020	500	20.83/4.35	5	5/8	143	5	133	4	114	5	7/8	149	4	3/8	111	.313 X 1.06	8 X 27	29.0	13.1
B750-2110-GAF	56037	750	31.25/6.52	6	5/8	168	6	162	6	152	5	1/16	129	5	5/16	135	.313 X 1.25	8 X 32	29.8	13.5
B1K0-2188-GAH	56044	1000	41.67/8.70	7	1/16	179	6	162	6	152	5	1/16	129	5	5/16	135	.313 X 1.25	8 X 32	30.2	13.7

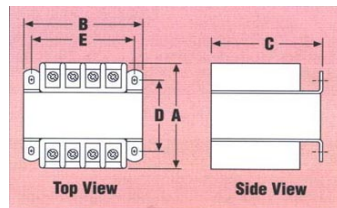

**DIMENSIONS: IMPERVITRAN
P/N BEGINNING "B"**

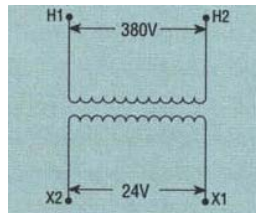

**CONNECTION DIAGRAM:
GROUP "G"**

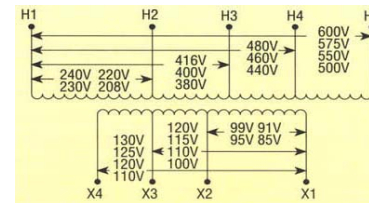

**CONNECTION DIAGRAM:
GROUP "H"**

**GLOBALTRAN:
GROUP "G"**

All meet EN 61558-2-2, are UL Listed, CSA Certified and 50/60 Hz

CATALOG NUMBER	UPC # 784550	OUTPUT		DIMENSIONS INCHES (MM)										MOUNTING SLOTS		APPROX. WEIGHT		
		VA	AMPS	A		B		C		D		E		IN	MM	LBS	KG	
VOLTAGE: PRI: 380 SEC: 24																		
B050-2051-GA	055672	50	2.08	3 3/8	86	3	76	3	76	2 3/16	56	2 1/2	64	.203 X .460	5 X 12	3.5	1.6	
B075-2052-GA	055689	75	3.13	3 3/8	86	3 3/8	86	3 1/4	83	2 3/16	56	2 13/16	71	.203 X .460	5 X 12	4.2	1.9	
B100-2053-GA	055696	100	4.17	3 3/8	86	3 3/4	95	3 1/2	89	2 7/16	61	3 1/8	79	.203 X .460	5 X 12	5.9	2.7	
B150-2054-GAF	056167	150	6.25	3 5/8	91	3 3/4	95	3 1/2	89	3	76	3 1/8	79	.203 X .460	5 X 12	7.3	3.3	
B200-2055-GAF	056068	200	8.33	3 3/4	95	4 1/2	114	4	102	2 13/16	71	3 3/4	95	.203 X .460	5 X 12	9.6	4.3	
B250-2056-GAF	056075	250	10.42	4	102	4 1/2	114	4	102	3 3/16	81	3 3/4	95	.203 X .460	5 X 12	11.3	5.1	
B300-2057-GAF	056181	300	12.50	4 3/8	111	4 1/2	114	4	102	3 3/4	95	3 3/4	95	.203 X .460	5 X 12	13.2	6.0	
B350-2058-GAF	056082	350	14.58	4 1/2	114	5 1/4	133	4 1/2	114	3 7/8	99	4 3/8	111	.313 X 1.06	8 X 27	14.9	6.7	
B500-2059-GAF	056099	500	20.83	5 1/8	130	5 1/4	133	4 1/2	114	3 7/8	99	4 3/8	111	.313 X 1.06	8 X 27	19.2	8.7	
B750-2060-GAF	056105	750	31.25	7	178	5 1/4	133	4 1/2	114	5 7/8	149	4 3/8	111	.313 X 1.06	8 X 27	29.8	13.5	

GROUP "H"

CATALOG NUMBER	UPC # 784550	OUTPUT		DIMENSIONS INCHES (MM)										MOUNTING SLOTS		APPROX. WEIGHT		
		VA	AMPS	A		B		C		D		E		IN	MM	LBS	KG	
VOLTAGE: PRI: 208-600 SEC: 85-130																		
B250-2283-GAF	054507	250	1.92	4 1/4	108	4 1/2	114	4	102	3 7/16	86	3 3/4	95	.203 X .460	5 X 12	11.4	5.2	
B300-2284-GAF	054552	300	2.31	4 3/4	121	4 1/2	114	4	102	3 3/4	95	3 3/4	95	.203 X .460	5 X 12	13.6	6.2	
B350-2285-GAF	054569	350	2.69	5	127	4 1/2	114	4	102	3 3/4	95	3 3/4	95	.203 X .460	5 X 12	14.2	6.4	
B500-2286-GAF	054576	500	3.85	5 1/2	140	5 1/4	133	4 1/4	108	3 7/8	99	4 3/8	111	.313 X 1.06	8 X 27	17.4	7.9	
B750-2287-GAF	054651	750	5.77	7 3/8	187	5 1/4	133	4 1/2	114	5 7/8	149	4 3/8	111	.313 X 1.06	8 X 27	27.5	12.4	
B1K0-2288-GAH	055061	1000	7.69	7	178	6 3/8	162	5 1/2	140	5 1/16	129	5 5/16	135	.313 X 1.25	8 X 32	27.9	12.6	
B1K5-2289-GAH	055078	1500	11.54	7 3/4	199	6 3/4	171	6	152	5	127	6 1/8	156	.313 X .91	8 X 23	43.1	19.5	
B2K0-2290-GAH	055085	2000	15.38	7 5/8	194	9	229	8	203	4 13/16	122	7 1/2	191	.44 X .91	11 X 23	56.0	25.3	
B3K0-2291-GAH	055405	3000	23.08	8 9/16	217	9	229	7 5/8	194	5 3/4	146	7 1/2	191	.44 X .91	11 X 23	76.2	34.5	

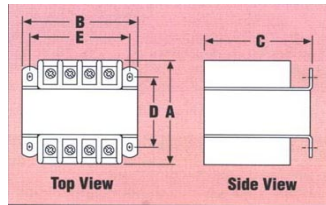

**DIMENSIONS: IMPERVITRAN
P/N BEGINNING "B"**

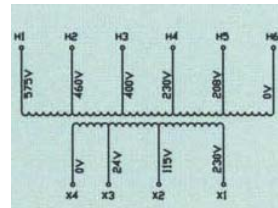

**CONNECTION DIAGRAM:
GROUP "I"
Through 1 Kva**

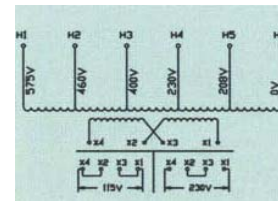

**CONNECTION DIAGRAM:
GROUP "I"
Above 1 Kva**

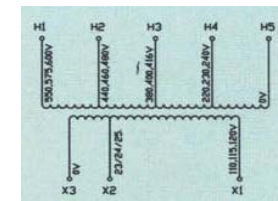

**CONNECTION DIAGRAM:
GROUP "J"**

All meet EN 61558-2-2, are UL Listed, CSA Certified and 50/60 Hz

GLOBALTRAN: GROUP "I"		OUTPUT		DIMENSIONS INCHES (MM)					MOUNTING SLOTS		APPROX. WEIGHT						
CATALOG NUMBER	UPC # 784550	VA	AMPS	A		B		C		D		IN	MM	LBS	KG		
				IN	MM	IN	MM	IN	MM	IN	MM	IN	MM				
VOLTAGE:																	
PRI: 208/230/400/460/575																	
SEC: 24*/115/230																	
B250-2263-GAF	055443	250	10.4/2.2/1.1	4 3/4	121	4 1/2	114	4	102	4 3/4	121	3 3/4	95	.203 X .844	5 X 21	14.9	6.7
B300-2264-GAF	055450	300	12.5/2.6/1.3	5 1/4	133	4 1/2	114	4	102	4 3/4	121	3 3/4	95	.203 X .844	5 X 21	17.4	7.9
B350-2265-GAF	055467	350	14.6/3.0/1.5	5 3/8	137	5 1/4	133	4 1/2	114	4 3/8	111	4 3/8	111	.31 X 1.06	8 X 27	17.8	8.1
B500-2266-GAF	056129	500	20.8/4.3/2.2	6 5/8	168	5 1/4	133	4 1/2	114	5 7/8	149	4 3/8	111	.31 X 1.06	8 X 27	26.6	12.0
B750-2267-GAF	056136	750	31.3/6.5/3.3	7 7/16	189	6 3/8	162	6	152	5 1/16	129	5 5/16	135	.31 X 1.25	8 X 32	32.5	14.7
B1K0-2268-GAH	056235	1000	41.7/8.7/4.3	7 3/4	199	6 3/4	171	6 1/4	159	5	127	6 1/8	156	.31 X .91	8 X 23	44.0	19.9
B1K5-2269-GAH	056266	1500	13.04/6.52	7 3/4	199	6 3/4	171	6	152	5	127	6 1/8	156	.31 X .91	8 X 23	45.4	20.5
B2K0-2270-GAH	056273	2000	17.39/8.70	7 5/8	194	9	229	7 5/8	194	4 13/16	122	7 1/2	191	.44 X .91	11 X 23	58.6	26.5
B3K0-2271-GAH	056280	3000	26.09/13.04	8 3/4	222	9	229	7 5/8	194	5 15/16	151	7 1/2	191	.44 X .91	11 X 23	92.9	42.0
B5K0-2272-GAH	056884	5000	43.48/21.74	10 7/16	265	9	229	7 5/8	194	7 5/8	194	7 1/2	191	.44 X .91	11 X 23	127.4	57.6

* 24 AVAILABLE THROUGH 1Kva

GROUP "J"		OUTPUT		DIMENSIONS INCHES (MM)					MOUNTING SLOTS		APPROX. WEIGHT						
CATALOG NUMBER	UPC # 784550	VA	AMPS	A		B		C		D		IN	MM	LBS	KG		
				IN	MM	IN	MM	IN	MM	IN	MM	IN	MM				
VOLTAGE:																	
PRI: 230/400/460/575																	
SEC: 24/115																	
B250-2243-GAF	054873	250	10.4/2.2	4 3/4	121	4 1/2	114	4	102	3 3/4	95	3 3/4	95	.203 X .844	5 X 21	14.3	6.5
B300-2244-GAF	054880	300	12.5/2.6	5	127	4 1/2	114	4	102	4 3/4	121	3 3/4	95	.203 X .844	5 X 21	15.8	7.1
B350-2245-GAF	054897	350	14.6/3.0	5 1/8	130	5 1/4	133	4 1/2	114	3 7/8	99	4 3/8	111	.313 X 1.06	8 X 27	16.5	7.5
B500-2246-GAF	055016	500	20.8/4.3	5 3/4	146	5 1/4	133	4 1/2	114	4 7/8	124	4 3/8	111	.313 X 1.06	8 X 27	20.5	9.3
B750-2247-GAF	055023	750	31.3/6.5	7	178	6 3/8	162	6	152	5 1/16	129	5 5/16	135	.313 X 1.25	8 X 32	28.8	13.0
B1K0-2248-GAH	055054	1000	41.7/8.7	8 1/8	207	6 3/8	162	6	152	5 1/16	129	5 5/16	135	.313 X 1.25	8 X 32	39.4	17.8

GLOBALTRAN ACCESSORIES
A FULL LINE OF PRIMARY AND SECONDARY FUSING ACCESSORIES ARE AVAILABLE.
CONTACT MICRON FOR SPECIFIC PRICING

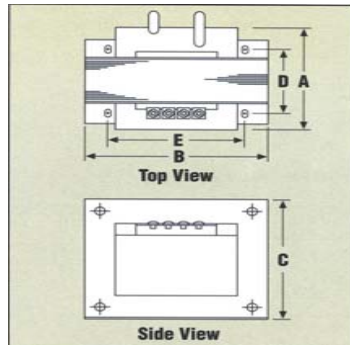

DIMENSIONS

Micron medium voltage control transformers have:

- * 130° C Insulation system.
- * 24" Minimum primary lead length.
- * 60Hz.
- * HIPOT - 7,400 volts for 2400 primary.
- * HIPOT - 11,500 volts for 4160 and 2400 primaries.
- * 750 VA - Epoxy impregnated coils.
- * 1 KVA and larger - Epoxy potted primary coils.

CONTROL TRANSFORMERS:		MEDIUM VOLTAGE		DIMENSIONS INCHES (MM)										MOUNTING SLOTS		APPROX. WEIGHT	
CATALOG NUMBER	UPC # 784550	OUTPUT VA	AMPS	A		B		C		D		E		IN	MM	LBS	KG
				IN	MM	IN	MM	IN	MM	IN	MM	IN	MM	IN	MM		
*PRI: 4200 PRI: 2400 SEC: 120																	
H750-0030	* 027587	750	6.25	6 5/8	168	6 3/8	162	5 13/16	148	5 1/4	133	5 5/16	135	5/16 X 11/16	8 X 17	30.5	13.8
H750-0031	027594	750	6.25	6 5/8	168	6 3/8	162	5 13/16	148	5 1/4	133	5 5/16	135	5/16 X 11/16	8 X 17	30.7	13.9
*PRI: 4160 PRI: 2400 SEC: 120/240																	
H1K0-0010	027518	1000	8.33/4.17	6 1/4	159	7 9/16	192	6 3/8	162	3 1/2	89	5 5/8	143	3/8 X 5/8	10 X 16	31.3	14.2
H1K0-0015	* 027532	1000	8.33/4.17	6 1/4	159	7 9/16	192	6 3/8	162	3 1/2	89	5 5/8	143	3/8 X 5/8	10 X 16	31.1	14.1
HN1K5F1519P	027662	1500	12.50/6.25	7	178	9	229	7 5/8	194	4 1/4	108	6 1/2	165	7/16 X 3/4	11 X 19	53.7	24.4
HN1K5G1519P	* 027679	1500	12.50/6.25	7	178	9	229	7 5/8	194	4 1/4	108	6 1/2	165	7/16 X 3/4	11 X 19	52.2	23.7
HN2K0F1519P	027686	2000	16.67/8.33	7 15/16	202	9	229	7 5/8	194	5 3/16	132	6 1/2	165	7/16 X 3/4	11 X 19	65.4	29.7
HN2K0G1519P	* 027693	2000	16.67/8.33	7 15/16	202	9	229	7 5/8	194	5 3/16	132	6 1/2	165	7/16 X 3/4	11 X 19	58.2	26.1
HN3K0F1519P	027709	3000	25.00/12.50	9 3/4	248	9	229	7 5/8	194	7	178	6 1/2	165	7/16 X 3/4	11 X 19	99.9	45.3
HN3K0G1519P	* 027716	3000	25.00/12.50	9 3/4	248	9	229	7 5/8	194	7	178	6 1/2	165	7/16 X 3/4	11 X 19	101.0	45.8

UL OVERCURRENT PROTECTION - PRIMARY

Overcurrent protection on both the primary and secondary sides of transformers are specified in UL 508 and the National Electric Code. The maximum acceptable ratings are shown below. Due to the high inrush currents present when a transformer is initially energized, it is recommended that the primary fuses be time delay, to prevent nuisance trips during start-up.

MAXIMUM ACCEPTABLE RATING OF PRIMARY OVERCURRENT PROTECTION

Primary Voltage	VA Rating										
	25	50	75	100	150	200	250	300	350	500	750
115	6/10 (1)	1-1/4 (2)	1-8/10 (3-2/10)	2-1/2 (4)	3-1/2 (6-1/4)	5 (8)	5	6-1/4	7-1/2	10	15
120	6/10 (1)	1-1/4 (2)	1-8/10 (3)	2-1/4 (4)	3-1/2 (6-1/4)	5 (8)	5	6-1/4	7	10	15
200	3/10 (6/10)	3/4 (1-1/4)	1-1/8 (1-8/10)	1-1/2 (2-1/2)	2-1/4 (3-1/2)	3 (5)	3-1/2 (6-1/4)	4-1/2 (7-1/2)	5 (8)	6-1/4	9
208	3/10 (6/10)	6/10 (1-1/8)	1 (1-8/10)	1-4/10 (2-1/4)	2 (3-1/2)	2-8/10 (4-1/2)	3-1/2 (6)	4 (7)	5 (8)	6	9
220	3/10 (1/2)	6/10 (1-1/8)	1 (1-6/10)	1-1/4 (2-1/4)	2 (3-2/10)	2-1/2 (4-1/2)	3-2/10 (5-6/10)	4 (6-1/4)	4-1/2 (7-1/2)	5-6/10	8
230	3/10 (1/2)	6/10 (1)	8/10 (1-6/10)	1-1/4 (2)	1-8/10 (3-2/10)	2-1/2 (4)	3-2/10 (5)	3-1/2 (6-1/4)	4-1/2 (7-1/2)	5	8
240	3/10 (1/2)	6/10 (1)	8/10 (1-1/2)	1-1/4 (2)	1-8/10 (3)	2-1/4 (4)	3 (5)	3-1/2 (6-1/4)	4 (7)	5	7-1/2
277	1/4 (4/10)	1/2 (8/10)	8/10 (1-1/4)	1 (1-8/10)	1-6/10 (2-1/2)	2 (3-1/2)	2-1/2 (4-1/2)	3-2/10 (5)	3-1/2 (6-1/4)	5 (9)	6-1/4
380	3/16 (3/10)	3/10 (6/10)	1/2 (8/10)	3/4 (1-1/4)	1-1/8 (1-8/10)	1-1/2 (2-1/2)	1-8/10 (3-2/10)	2-1/4 (3-1/2)	2-1/2 (4-1/2)	3-1/2 (6-1/4)	5-6/10 (9)
400	3/16 (3/10)	3/10 (6/10)	1/2 (8/10)	3/4 (1-1/4)	1-1/8 (1-8/10)	1-1/2 (2-1/2)	1-8/10 (3)	2-1/4 (3-1/2)	2-1/2 (4)	3-1/2 (6-1/4)	5-6/10 (9)
415	15/100 (3/10)	3/10 (6/10)	1/2 (8/10)	6/10 (1-1/8)	1 (1-8/10)	1-4/10 (2-1/4)	1-8/10 (3)	2 (3-1/2)	2-1/2 (4)	3-1/2 (6)	5 (9)
440	15/100 (1/4)	3/10 (1/2)	1/2 (8/10)	6/10 (1-1/8)	1 (1-6/10)	1-1/4 (2-1/4)	1-6/10 (2-8/10)	2 (3-2/10)	2-1/4 (3-1/2)	3-2/10 (5-6/10)	5 (8)
460	15/100 (1/4)	3/10 (1/2)	4/10 (8/10)	6/10 (1)	8/10 (1-6/10)	1-1/4 (2)	1-6/10 (2-1/2)	1-8/10 (3-2/10)	2-1/4 (3-1/2)	3-2/10 (5)	4-1/2 (8)
480	15/100 (1/4)	3/10 (1/2)	4/10 (3/4)	6/10 (1)	8/10 (1-1/2)	1-1/4 (2)	1-1/2 (2-1/2)	1-8/10 (3)	2 (3-1/2)	3 (5)	4-1/2 (7-1/2)
550	1/8 (2/10)	1/4 (4/10)	4/10 (6/10)	1/2 (8/10)	8/10 (1-1/4)	1 (1-8/10)	1-1/4 (2-1/4)	1-6/10 (2-1/2)	1-8/10 (3)	2-1/2 (4-1/2)	4 (6-1/4)
575	1/8 (2/10)	1/4 (4/10)	3/10 (6/10)	1/2 (8/10)	3/4 (1-1/4)	1 (1-6/10)	1-1/4 (2)	1-1/2 (2-1/2)	1-8/10 (3)	2-1/2 (4)	3-1/2 (6-1/4)
600	1/8 (2/10)	2/10 (4/10)	3/10 (6/10)	1/2 (8/10)	3/4 (1-1/4)	8/10 (1-6/10)	1-1/4 (2)	1-1/2 (2-1/2)	1-6/10 (2-8/10)	2-1/4 (4)	3-1/2 (6-1/4)

If the rated primary current is less than 2 amps, the maximum rating of the overcurrent device is 300% for power circuits, shown above, or 500% for control circuits, shown above in *(brackets)*. If the rated primary current is 2 amps or more, the maximum rating of the overcurrent device is 250%. All figures assume secondary overcurrent protection per UL/NEC.

Reference: NEC 430-72(c) exception #2; 450-3(b) 1 & 2; UL508, 32.7; UL 845, 11.16 & 11.17.

UL OVERCURRENT PROTECTION - SECONDARY**MAXIMUM ACCEPTABLE RATING OF SECONDARY OVERCURRENT PROTECTION**

Secondary Voltage	VA Rating										
	25	50	75	100	150	200	250	300	350	500	750
23	1-8/10	3-1/2	5	7	10	12	15	20	20	30	45
24	1-6/10	3-2/10	5	6-1/4	10	12	15	20	20	30	40
25	1-6/10	3-2/10	5	6-1/4	10	12	15	15	20	25	40
90	4/10	8/10	1-1/4	1-8/10	2-1/2	3-1/2	4-1/2	5	6-1/4	9	12
95	4/10	8/10	1-1/4	1-6/10	2-1/2	3-1/2	4	5	6	8	12
100	4/10	8/10	1-1/4	1-6/10	2-1/2	3-2/10	4	5	5-6/10	8	12
110	3/10	3/4	1-1/8	1-1/2	2-1/4	3	3-1/2	4-1/2	5	7-1/2	10
115	3/10	6/10	1	1-4/10	2	2-8/10	3-1/2	4	5	7	10
120	3/10	6/10	1	1-1/4	2	2-1/2	3-2/10	4	4-1/2	6-1/4	10
220	15/100	3/10	1/2	3/4	1-1/8	1-1/2	1-8/10	2-1/4	2-1/2	3-1/2	5-6/10
230	15/100	3/10	1/2	6/10	1	1-1/4	1-6/10	2	2-1/4	3-2/10	5
240		3/10	1/2	6/10	1	1-1/4	1-6/10	2	2-1/4	3-2/10	5

If the rated secondary current is less than 9 amps, the maximum rating of the overcurrent device is 167%; 9 amps or more, the maximum rating of the overcurrent device is 125%. If 125% does not correspond to a standard fuse rating, the next highest standard rating may be used.

Reference: NEC 430-72(c) exception #2; 450-3(b) 1 & 2; UL 508, 32.7; UL 845, 11.16 & 11.17.



Micron Industries Corporation

777 North Church Road

Elmhurst, IL 60126

Phone: 800-664-4660

FAX: 630-516-1820

www.microntransformers.com